

Waste Management System Free Standing Intake Station - 750x700 mm

ITEM # _____

MODEL # _____

NAME # _____

SIS # _____

AIA # _____

616024 (WMSIS77PF)

 Intake station (750x700mm)
 with pump, 450 kg/hr, free
 standing

Short Form Specification

Item No. _____

For the break-up of daily food waste so that it can be transported with water to the holding tanks. Food can be put in continuously via the open trough. The grinder is equipped with 2 protection systems. An overload protection system prevents the motor from overheating when too much food is introduced and a magnetic system blocks the flatware if introduced accidentally. The centrifugal propeller below the grinding teeth ensures an increased output and no pipe blockage when the waste is transferred. The control panel incorporates on/off and emergency cut-out buttons. Free standing.

Main Features

- Capacity of 450 kg per hour and 750x700 mm dimensions to match the working environment's space constraints.
- Intake station to be used in medium and large modular systems (only one or multiple intake stations, one or multiple storing tanks and one dewatering press).
- Used to break-up organic waste, allowing water transportation to the holding tanks.
- Self cleaning cycle with warm water and a small quantity of neutral soap.
- Cutlery magnet to avoid magnetic objects from accidentally entering the grinder.
- Grinder to have overload protection system to protect the motor from overheating.
- Propeller pump transports waste into the circuit through hoses connected to the storing tank and guarantees an increased output with no pipe blockage.
- On/off button and emergency cut-out button on control panel.
- Standard cycle setting of 2 minutes, adaptable to operator's needs.

Construction

- Grinding ring in 304 AISI stainless steel, 4 mm in spacing to provide small food particles.
- Grinding teeth positioned at the same height to maximize cutting performance and speed.
- Two pivoted stainless steel cutting blades to avoid blockage.

APPROVAL: _____

Front

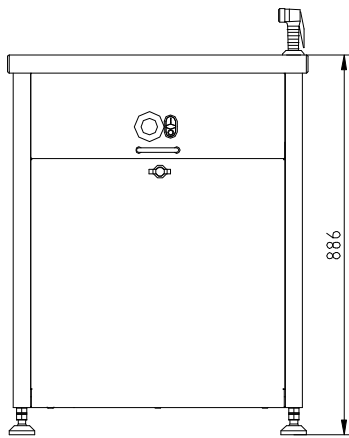
Electric
Supply voltage:

616024 (WMSIS77PF)

400 V/3N ph/50/60 Hz

Total Watts:

3.3 kW

Key Information:
Performance:

450 kg\hr

External dimensions, Width:

700 mm

External dimensions, Height:

886 mm

External dimensions, Depth:

750 mm

Net weight:

158 kg

Side

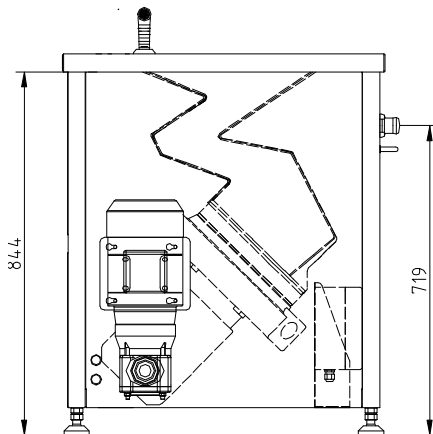

- CWI1 = Cold Water inlet 1 (cleaning)
- D = Drain
- EI = Electrical inlet (power)
- EO = Electrical Outlet
- HWI = Hot water inlet
- WI = Water inlet

Top

